

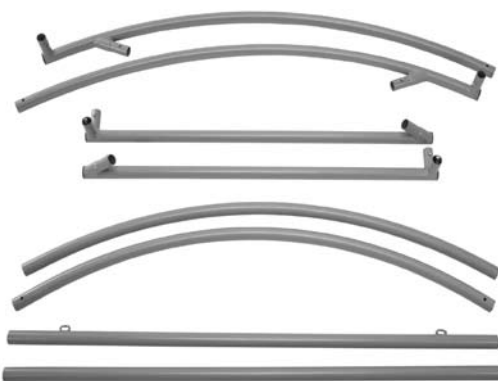

Steel Double Swing Stand

Weight limit: 450 pounds

Congratulations on your purchase of this quality Hatteras Hammocks® product! **QUESTIONS?** Call our customer-service line toll-free at (800) 643-3522.



Before beginning assembly, check that you have all parts.

Your box should contain:

- 2 - Curved Upright Back Poles- 2 Arm Attachments
- 2 - Straight Base Side Poles- 3 Arm Attachments
- 2 - Curved Arm Poles
- 1 - Straight Front Pole- Hanging Rings
- 1 - Straight Base Back Pole- No Rings
- 2 - S-Hooks (pictured in FIGURE 7, below right)

Helpful for assembly:



Rubber mallet (not included)

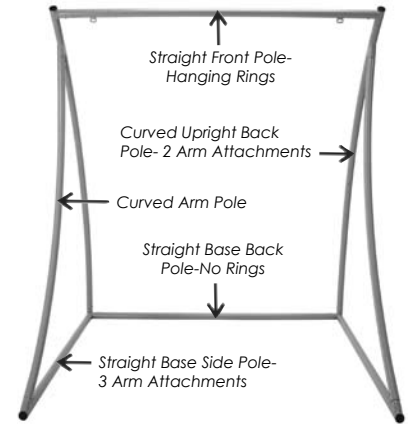

▶ ▶ ▶ **This stand can be assembled by one person alone, but it's a whole lot easier if you've got an extra set of arms for help!**

STEP 1. Set the two **Straight Base Side Poles-3 Arm Attachments** roughly parallel to each other about 6 feet apart. The poles should sit upright easily, with one arm attachment on each settled flush with the floor. Using the spring pins, connect the **Straight Base Back Pole-No Rings** between the two Straight Base Side Pole arm attachments flush with the floor (FIGURE 1); this will create the stand's base.

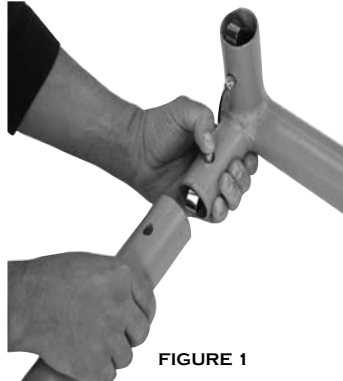

FIGURE 1

STEP 2. Connect the two **Curved Arm Poles** to the stand base you created in the previous step. The Curved Arm Poles connect using spring pins to the arm attachments facing upward at the front of each of the two **Straight Base Side Poles-3 Arm Attachments** (FIGURE 2).



FIGURE 2



FIGURE 5

STEP 4. To complete your stand, use the spring pins to connect the **Straight Front Pole-Hanging Rings** between the two remaining arm attachments at the top of the **Curved Upright Back Poles-2 Arm Attachments** (FIGURE 5).

STEP 3. Connect a **Curved Upright Back Pole-2 Arm Attachments** to each remaining upright arm attachment at the back of the stand's base (FIGURE 3). Do NOT latch the spring pin, because as you're connecting the Curved Upright Back Pole to the base, you also want to line up that back pole's downward-facing arm attachment with the top of a **Curved Arm Pole** (FIGURE 4). This is where someone else's aid is really useful, to help guide the poles. Once both poles are connected, lock the spring pins.

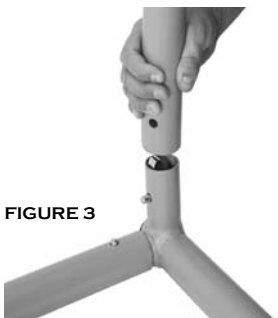



FIGURE 3 FIGURE 4

It may be necessary to tap the poles into place with a rubber mallet to lock the spring pins (do NOT use a metal-headed hammer; this could damage the protective Cape Shield® Powder Coat).

STEP 5. With your stand assembled (FIGURE 6), place the two included **S-Hooks** onto the small metal half-rings in the center of the **Straight Front Pole-Hanging Rings** (FIGURE 7). Your swing's hanging chains will fit onto these S-Hooks.

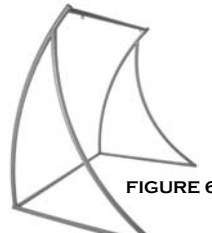

FIGURE 6



FIGURE 7

WARRANTY | Product guaranteed free of defects in workmanship and materials for up to one year from date of purchase. If an item is found to be defective within that time, The HammockSource will replace it at no charge. Normal wear and tear, including prolonged exposure to snow, rain and heavy humidity, is not covered, nor is mold, mildew or damage from improper storage, maintenance or installation. An original sales receipt must accompany any returned product, along with a Return Authorization Number from HammockSource customer service; call toll-free at (800) 643-3522. 012011